

REVISION RECORD			
REV	ECN	DESCRIPTION	DFT DATE

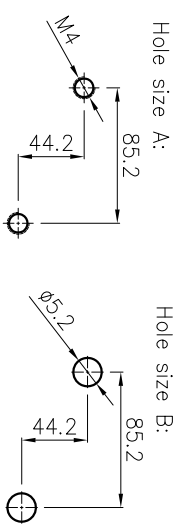
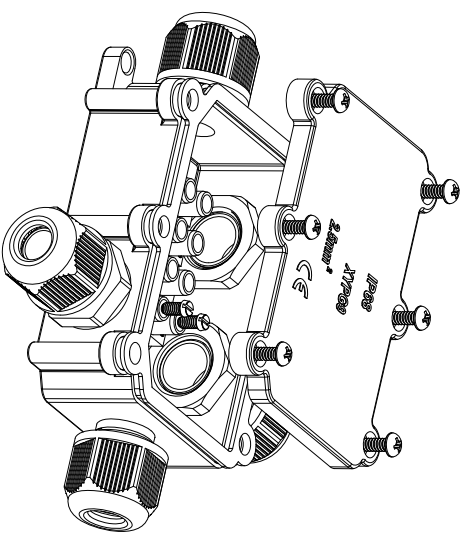
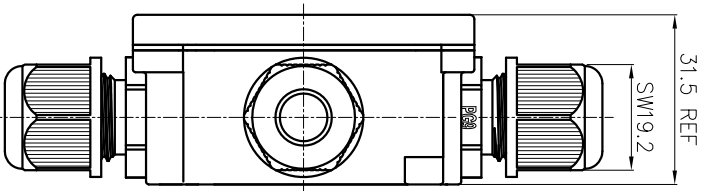
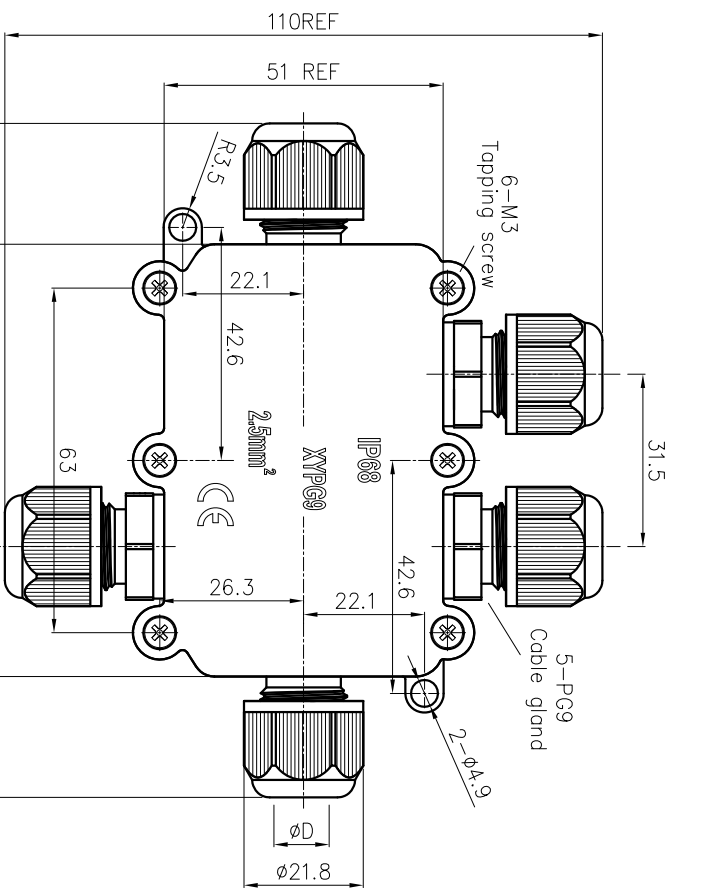

Technique parameter-5 P	
Rated voltage	450V
Rated current	16A
Insulation resistance	≥100MΩ
Withstanding voltage	1200VAC
Operating temperature	-40°C~+85°C
Levels of protection	IP68
Cable OD.	Ø4.2~7.8

- NOTES:
1. RoHS Compliance,
 2. The Code direction is shown as diagram,
 3. ⊗ "Point advertent place,
 4. Screw material: Steel,
 5. Supporter material: Cu, plating: Ni,
 6. Nut material: PA66 /PA66+GF ,
 7. O ring: SI/NBR. Color: white/black,
 8. Housing material: PA66. Color: black,
 9. Scope wiring: 1.0~2.5mm².

尺寸公差(mm)			
≤30	30 ~ 60	60 ~ 100	100 ~ 150
±0.20	±0.30	±0.50	±0.70
			±1.00

DETACHED LISTS	
PART NO.:	20139000004
APPD:	YX-H Series
CHKD:	
DFT:	WYM 2019/06/20
THIRD ANGLE PROJECTION	

NAME:	
NINGBO DEGSON ELECTRICAL CO., LTD	
宁波高松电子有限公司	
YX-H-05P-PG9-4	
TITLE:	ASSEMBLY DRAWING
DRAWING NO.:	XX
DO NOT SCALE DRAWING	
SCALE	1:1